

Vehtec System Installation

- *Service Vehicles* -

VEHTEC

Designing good climate

www.VEHTEC.se +46 31-78 78 900 info@vehtec.se

Materials and tools

It is very important that you have the proper system components and tools when you mount Vehtec's heating system. If you do not use the right materials and tools, your vehicle or your heating system may be damaged and Vehtec cannot guarantee that your system will work properly and cannot cover any warranties on your products.

Recommended tools

- Electric screwdriver or similar and screws for mounting Compact Climate.
- Measuring tape
- Hole saw, drill
- Hose clamp tools / clamp tongs
- Hose cutter
- Proper safety equipment / safety glasses

Vehtec's Heating System

Each system component is completely assembled when you receive your Vehtec order. Mount and connect the components based on your design plans. Vehtec can design your heating system based on your input if requested. We also can send a technician to oversee your first installation if necessary.

For optimal performance we recommend the following:

- Temperature of the cooling water should be between 75-95 ° C
- Flow rate of cooling water should be at least 20L/min (900L / h)
- Low back pressure in the system (right size valves, hoses, minimal bends)
- Some form of system control (thermostat, mixing valve etc.)
- No air bubbles in system
- Components are securely mounted to the vehicle and connected properly

Page 3 features recommended system for SERVICE VEHICLES. Your system may differ than the one listed

VEHTEC

Designing good climate

www.VEHTEC.se +46 31-78 78 900 info@vehtec.se

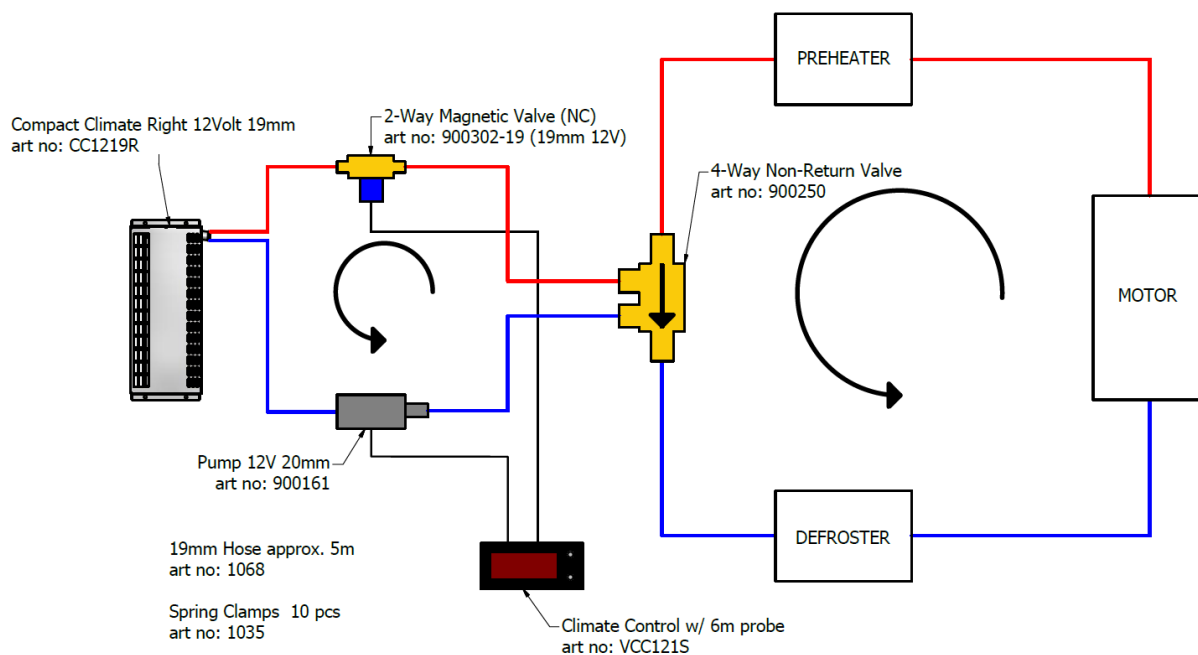

Vehtec's Recommended Service Vehicle Kit includes:

- 1pc Compact Climate (Left or Right, 12 or 24 volt, 19 or 16mm)
- 1pc 4-Way Non Return Valve
- 1pc Magnetic Valve NC (12 or 24 Volt, 19 or 16mm)
- 1pc Pump (12 or 24volt, 20 or 16mm)
- 1pc Climate Control w/ 6m Probe (12 Volt)
- 5m Hose (22, 19, or 16mm ID)
- 10 pcs Spring clamps (for 22,19, or 16mm ID hoses)

System Description

- 1) Water is heated up from motor/preheater and travels to 4-way valve
- 2) If Climate Control is off, then pump and 2-way valve are off and water travels through 4-way valve to defroster
- 3) If Climate Control is on and probe temperature is *under* specified temp, then pump turns on and 2-way valve opens. Water flows toward Compact Climate from 4-way valve. Compact Climate expels hot air. Return water flows to 4-way valve and back toward motor.
- 4) If Climate Control is on and probe temperature is *over* specified temp, pump turns off and 2-way valve closes until specified temperature is reached. Water flows through 4-way valve to defroster.

If you need help with your installation or have questions about your heating system design, you are always welcome to contact Vehtec through mail or telephone. Info@vehtec.se +46 31-78 78 900

VEHTEC

Designing good climate

www.VEHTEC.se +46 31-78 78 900 info@vehtec.se

Troubleshooting

- **Water is not flowing back to the motor**
 - ✓ Is the 4-way valve mounted in the correct direction? Observe the arrow etched into the valve.

- **The system is leaking**
 - ✓ Are you using spring clamps? Vehtec highly recommends the use of these clamps (see pg. 18 of Vehtec's catalogue). These clamps provide a tight grip around the hose while allowing for hose expansion and contraction due to temperature changes. Screw clamps do not allow for this and unfortunately can result in an imperfect seal or lead to fractures in the hose's lining.
 - ✓ Are your clamps the correct size?
 - ✓ Are clamp connections securely fastened to pipes?
 - ✓ Is the hose the correct diameter? Additionally, we recommend using Vehtec's rubber hose (catalogue pg.19) in conjunction with our other components.

- **Water is not flowing to the blower**
 - ✓ Is the 2-way valve functioning properly? Check that the valve is installed in the correct direction and more importantly it should be in a protected place. If it is installed underneath the vehicle, ensure that it is protected and not susceptible to physical damage. Additionally ensure the valve is either 12 or 24 volt depending on the vehicles voltage.
 - ✓ Is the pump functioning properly? Check that the pump is installed in the correct direction and more importantly it should be in a protected place. If it is installed underneath the vehicle ensure that it is protected and not susceptible to physical damage. The pump should also be mounted in a way to avoid air pockets (see figure). Additionally ensure the pump is either 12 or 24 volt depending on the vehicles voltage.
 - ✓ Are both the pump and 2-way valve connected to a climate control? Otherwise, the 2-way valve is normally closed and pump will not start when then are not connected to power.

- **The vehicle is not heating up to the specified temperature**
 - ✓ Is the temperature probe placed properly? The probe should be placed away from the blower. Otherwise the heater will continue to shut off prior to reaching the specified temperature. Place the probe as close to the center of the vehicle as possible.

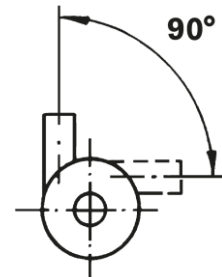

If you have attempted to correct these issues and the problem persists do not hesitate to contact Vehtec through mail or telephone. info@vehtec.se +46 31-78 78 900

VEHTEC

Designing good climate

www.VEHTEC.se +46 31-78 78 900 info@vehtec.se